



John Wood® Power Vent™ Water Heaters

The John Wood® Power Vent™ water heater is designed with an ultra quiet blower and state-of-the-art gas control with advanced self-diagnostics for quick and easy servicing. Our models are perfect for both residential new home construction and replacement water heater applications; the John Wood® Power Vent™ provides the ideal solution for your hot water needs.

Product Features

- Turbulator™ dip tube for self-cleaning, reducing sediment at the bottom of the tank and increasing hot water output by as much as 8%
- Over 20% more foam insulation and higher EF for energy and cost savings
- Relocated T&P and drain valve for ease of installation and serviceability

Safety Features

- Flammable vapour sensor detects the presence of flammable vapours and automatically disables the unit preventing their ignition
- The only flammable vapour sensor in the industry that is protected from contaminants
- Robust air intake snorkel inhibits flammable vapours from entering the sealed combustion chamber

Serviceability

- State-of-the-art modular gas control features advanced self-diagnostic capability that makes troubleshooting easy

Water Heater Features

- Compact design – ideal as a replacement water heater and for closet installations
- Exclusive patented TankSaver® design to prolong tank life
- Convenient 3/4" side taps for combination applications on G5065S and G5065L

The Ultimate in Venting Flexibility

- All units can be vented horizontally through the wall or vertically through the roof with plastic venting pipe certified for gas-fired appliances



An advanced line of power vented water heaters.

CAPACITY & PERFORMANCE

Model Natural Gas 8 & 2 Year Warranty	Model Liquid Propane 6 & 1 Year Warranty	Capacity USG (Litres)	Input BTU	Recovery @ 100°F/45°C Rise USG/h (Litres/h)	Energy Factor	Shipping Weight lb (kg)
JW840NVH-ES	6G40PVH-ES	40 (151)	33,000	30 (112)	0.64	115 (70)
JW850NVH-ES	6G50PVH-ES	50 (189)	38,000	34 (129)	0.62	187 (85)
JW85065SNV-ES*	6G5065SPV-ES*	50 (189)	65,000	55 (209)	0.62	200 (90)
JW85065LNV-ES*	N/A	50 (189)	65,000	50 (188)	0.62	200 (90)
JW860NVH-ES	6G60PVH-ES	60 (227)	42,000	38 (144)	0.62	202 (92)

ROUGH-IN DIMENSIONS

Model Natural Gas 8 & 2 Year Warranty	Model Liquid Propane 6 & 1 Year Warranty	Height to top of blower	Height to top of tank	Height to T&P valve & side tap	Height to drain valve & side tap	Height to gas inlet	Diameter F in (cm)	Overall Depth G in (cm)	Vent Diameter H in (cm)
		A in (cm)	B in (cm)	C in (cm)	D in (cm)	E in (cm)			
JW840NVH-ES	6G40PVH-ES	58 (147)	48.5 (123)	41.38 (105)	9.63 (24.4)	14.5 (37)	21.13 (54)	26 (66)	2-3 (5-7.6)
JW850NVH-ES	6G50PVH-ES	60.5 (154)	51 (129.5)	44 (111)	10.63 (27)	15.38 (39)	22.63 (57)	27.25 (69)	2-3 (5-7.6)
JW85065SNV-ES*	6G5065SPV-ES*	60.75 (154)	51.25 (130)	44.13 (112)	10.63 (27)	15.5 (39.5)	22.63 (57)	27.25 (69)	3 (7.6)
JW85065LNV-ES*	N/A	51.25 (154)	51.25 (130)	44.13 (112)	10.63 (27)	15.5 (39.5)	22.63 (57)	27.25 (69)	3 (7.6)
JW860NVH-ES	6G60PVH-ES	67.5 (171.5)	58.25 (148)	51 (129.5)	10.63 (27)	15.5 (39.5)	22.63 (57)	27.25 (69)	2-3 (5-7.6)

* side taps

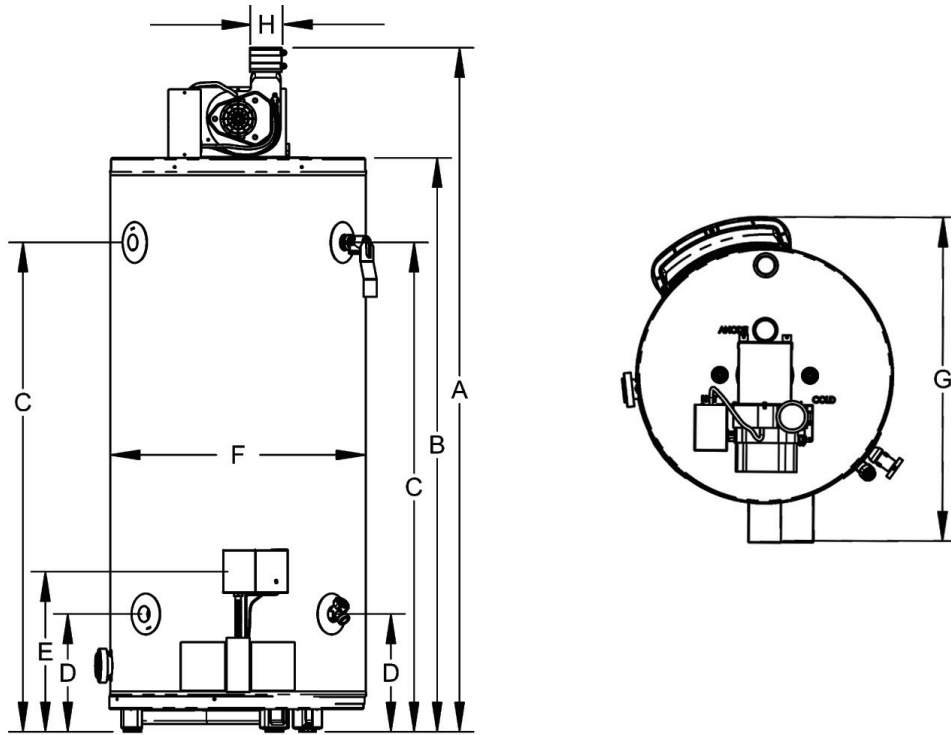

For more information, visit our website at:
www.johnwoodwaterheaters.com

GSW Water Heating

599 Hill Street West, Fergus, Ontario, Canada N1M 2X1
 Sales/Customer Service: 1-888-599-2837
 Fax: 1-519-787-5500
 Technical Support and Warranty: 1-888-479-8324
 E-mail: info@gsw-wh.com

GSW Warranty:

All GSW and John Wood® Water Heaters will be replaced free of charge in the case of tank leakage within the stated warranty period from the date of installation in domestic applications, and one year in commercial applications. All parts supplied are warranted for one year. Warranty does not include labour. Consult owner's manual for complete details.