



Introducing the John Wood® Series Pro Direct Vent™

A Unique Balanced Flue Design

Extensive research and development by GSW engineers has resulted in the creation of an innovative new approach to atmospherically vented gas water heaters; the John Wood® Direct Vent water heater design. A proven performer with ten years of laboratory testing and field trials including nine winters in the extreme cold, the Direct Vent operates quietly with no need for an electric fan or external power supply. The balanced flue design with a side wall vent termination allows installation in locations without a chimney. The sealed combustion chamber and co-axial vent uses fresh air taken from outside rather than pre-heated air from within the home. Quiet, reliable and efficient operation in a quality design: the John Wood® Direct Vent water heater.

Flame Safe™ technology – designed to protect the consumer against ignition of flammable vapours

HIGH QUALITY FEATURES

- No chimney needed
- Easy to install flexible co-axial vent supplied with water heater
- Removable anode(s)
- Meets latest energy efficiency standards
- Galvanized bottom pan protects from corrosion
- Complies with R2000 home requirements
- No external power supply required
- Glass-lined tank for longer life
- Factory-installed plastic-lined nipples with heat traps
- Automatic gas control
- CFC-free foam insulation
- **NEW 50 gallon high input for combo applications**



With TankSaver®

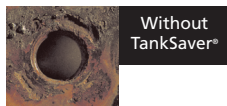

Without TankSaver®

Exclusive, patented innovation.

The exclusive and patented TankSaver® design works to prolong tank life. TankSaver® impedes corrosion by guarding metal tank openings from exposure and keeping them watertight. The durable construction virtually eliminates rust.

CAPACITY & DIMENSIONS

Model	Capacity USG (Litres)	BTU Input	Recovery @ 100°F/55°C Rise USG (Litres)	Energy Factor	Installation Height A in. (cm)	Height to Top of Heater B in. (cm)	Diameter C in. (cm)	Co-axial Vent D in. (cm)	Clearance to Combustibles* E in. (cm)	Max. Vent Length F in. (cm)	Approx. Shipping Weight lb. (kg)
NATURAL GAS - 8 and 2 Year Warranty											
JW840BFNA-FV	40 (151)	38,000	34 (129)	0.59	54.8 (139)	51.9 (131)	22.3 (57)	6 (15)	1 (2.5)	90 (229)	167 (76)
JW850TBFNA-FV	50 (189)	42,000	41.5 (135)	0.59	63.8 (161)	60.8 (154)	22.3 (57)	6 (15)	1 (2.5)	90 (229)	185 (84)
JW850THBFNA-FV**	50 (189)	50,000	42.4 (160)	0.59	64.8 (164)	62.3 (158)	22.3 (57)	6 (15)	1 (2.5)	90 (229)	187 (85)
PROPANE - 6 and 1 Year Warranty											
6G40BFP-FV	40 (151)	38,000	34 (129)	0.58	54.8 (139)	51.9 (131)	22.3 (57)	6 (15)	1 (2.5)	90 (229)	167 (76)
6G50TBFV-FV	50 (189)	42,000	41.5 (135)	0.58	63.8 (161)	60.8 (154)	22.3 (57)	6 (15)	1 (2.5)	90 (229)	185 (84)

* Zero clearance through outside walls.
 ** Side taps available on this model only.

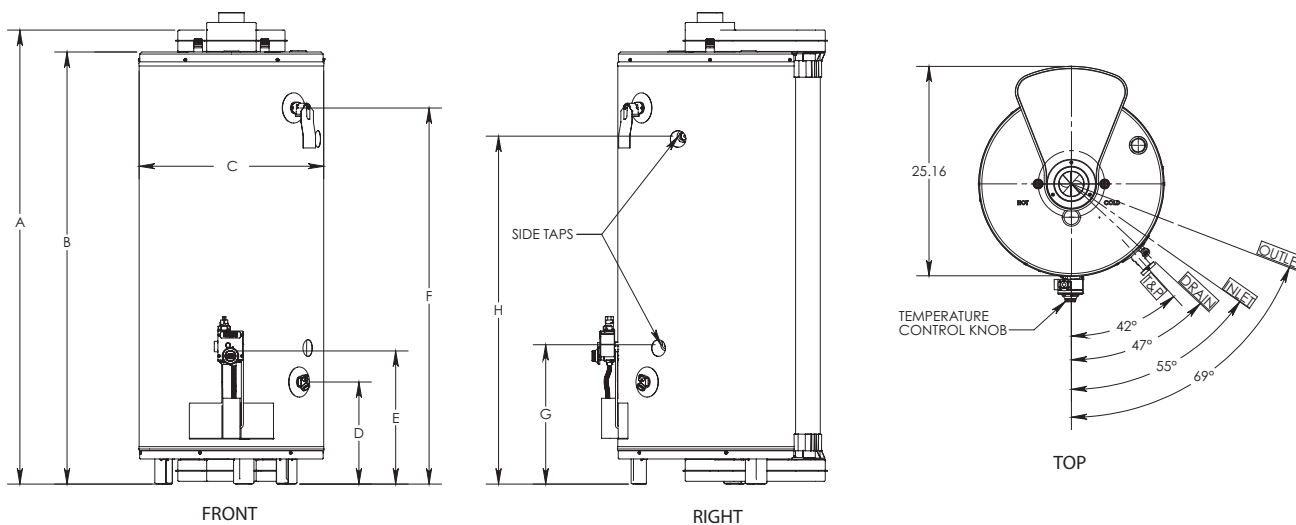

Please note: Above image is the new 50/50.



For more information,
 please visit our website at:
www.johnwoodwaterheaters.com

GSW Water Heating
 599 Hill Street West
 Fergus, Ontario, Canada N1M 2X1
 Sales/Customer Service: 1-888-599-2837
 Fax: 1-519-787-5500
 Technical Support and Warranty: 1-888-479-8324
 E-mail: info@gsw-wh.com

GSW Warranty:

All GSW and John Wood® Water Heaters will be replaced free of charge in the case of tank leakage within the stated warranty period from the date of installation in domestic applications, and one year in commercial applications. All parts supplied are warranted for one year. Warranty does not include labour. Consult owner's manual for complete details.

